

SIERRA DESIGNS

CLIP FLASHLIGHT



Your Sierra Designs CLIP FLASHLIGHT tent is very easy to pitch and maintain. Follow these instructions to pitch your tent quickly, safely and easily.

CLIP FLASHLIGHT TENT CONTENTS

Tent Body & Rainfly:	1	Pitching Instructions:	1
Tent Poles:	2	Stake Sack:	1
Tent Stakes:	9*	Pole Sack:	1
Guy Cord:	2		

* Sierra Designs tents include stakes for pitching the body and fly under normal conditions. Additional stakes may be required in severe conditions.

First Pitch

In order to familiarize yourself with your new tent, we suggest that you "test pitch" it before embarking on a wilderness trip.

Select a Site

Look for a level spot that is protected from the wind in order to ensure sleeping comfort. Clear the area of debris such as sharp stones and sticks which might abrade or puncture the tent floor. Choose an area that will drain well when it rains.

Unfurl the Tent and Assemble the Poles

Unfurl the tent and lay the tent floor flat on the ground with the door unzipped. Carefully unfold the shock corded pole sections and allow them to slide together. Do not allow the poles to snap together: This can lead to serious pole damage. Make certain that the insert of each pole section is fully inserted into the next pole section (Figure 1). You will have one long "front arch" pole and one short "rear arch" pole (Figure 2).

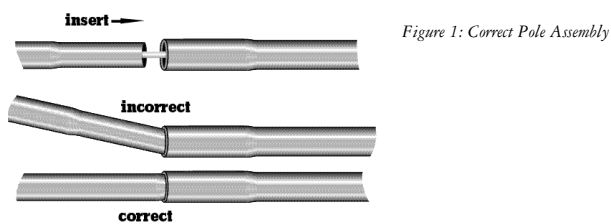

Figure 1: Correct Pole Assembly

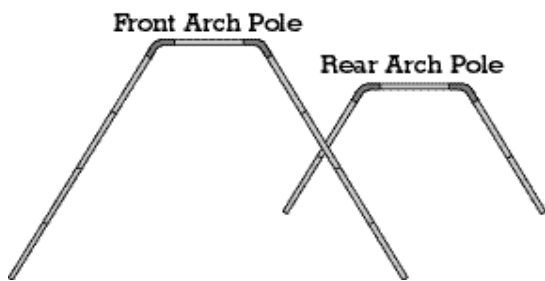

Figure 2: Arch Poles

Stake Out the Tent Floor

First stake down the webbing loops at the back of the tent at points G and H (Figure 3). Then move to the front of the tent and pull the webbing loops at points A and B until the floor is square and semi-taut, and stake them down. Staking out points C, D, E and F is recommended, especially in high winds.

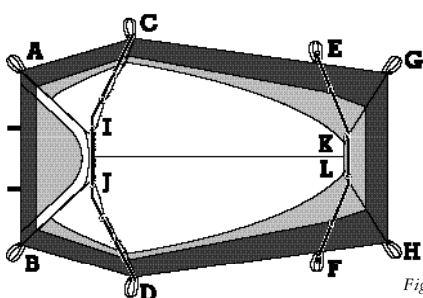

Figure 3: Tent Body (top view)



Erect the Tent

Insert the metal tips of the longer "front arch" pole into the grommets at points C and D (Figure 3). Clip the 2 Cam-Locs™ located above the door at points I and J onto the center section of the pole, taking care not to twist the webbing which connects the Cam-Loc to the tent. Do not engage the Cam-Loc at this time. Attach the remaining Swift

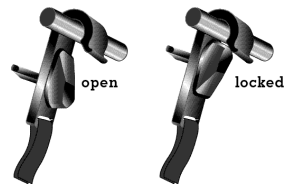
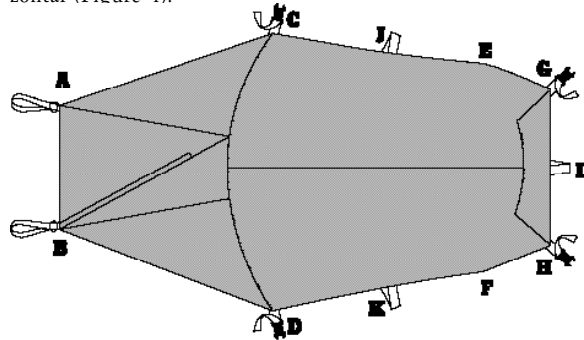

Figure 4: Cam-Loc™

Clips™, following the seam along the path of the pole, between points C and D. Now, insert the metal tips of the shorter "rear pole" into the grommets at points E and F. Attach the Cam-Locs at points K and L and Swift Clips™ to this pole in the same manner as the front pole. Once all the clips are attached to both poles you may engage the Cam-Locs by turning the key 180° until they lock completely onto the pole. When the Cam-Loc is engaged the key should be horizontal (Figure 4).



Flysheet

Drape the fly over the tent and position the zipper over the tent door (Figure 5). At points C, D, G and H are 1" side-release "fly clip" buckles. Clip these buckles into their corresponding mates on the tent floor and pull the straps until the fly is taut (Figure 6). By first clipping the blue webbing strap on the rainfly to a blue webbing strap on the body, you are guaranteed a fast, proper rainfly set-up every time. Now pull points A and B out until the vestibule is taut and stake it down in that position. You can use a guy line to guy out the fly at points I, J, and K for increased ventilation.

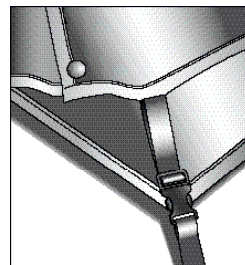

Figure 6: Fly Clip

Ventilation

The best air flow through the tent is obtained by pitching the tent with the foot area into the wind. With the rainfly on, air-flow is increased by guying out the rainfly away from the tent walls. Additionally, the door can be folded back and tied in an open position.